



**cubicle**.com

INSTALLATION INSTRUCTIONS

## General Information

This installation manual provides necessary information for the safe installation of Panel System product.

---

**WARNING:** Failure to follow the instructions in this manual can result in product damage, personal injury, or both.

---

---

**WARNING:** Installation of electrical components should be done by a qualified electrician. Disconnect power prior to servicing the system. Failure to do so can result in electric shock and/or personal injury.

---



Typical finished installation of the System 2 product

The System 2 product line is a modular panel system composed of panels, hanging and freestanding components and accessories designed to be precisely tailored to the office environment. It consists of products that are factory assembled and require installation only; and other products that are shipped as subassemblies for assembly during the installation process.

System 2 products are available with an 8-wire electric system that is listed with Underwriters Laboratories and comply with UL1286.

This product is considered portable furniture and is therefore subject to local fire, electrical and building codes; therefore, check with local building authorities before installation of the product.

It is the responsibility of the dealer and the installer to properly install this product according to this manual and generally accepted industry practices.

## Product Assembly

Panels/Connectors	4
Electrical	9
Storage/Shelves/ Flipper Doors	19
Work Surfaces	22
Pedestal/File Cabinets	25
Accessories	26

---

## SPECIAL NOTES:

- ☛ Please note all **TIPs**, as these are for your safety.
- ☛ Always use proper tools when installing.
- ☛ Keep your work area clean, clutter-free and safe during installation.
- ☛ Use eye protection when working under a workstation or when working with tools.
- ☛ **NOTE:** many products weigh more than 35 pounds. Use two or more people to safely lift, carry and install the products.
- ☛ When using tools, extension cords or ladders, use them in accordance to OSHA guidelines.
- ☛ Work safe, work smart.

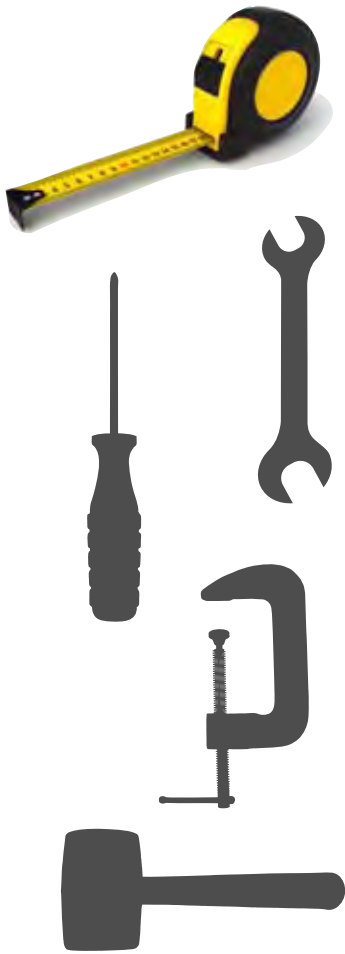

## GENERAL TOOLS FOR INSTALL

The following tools are necessary for field assembly and installation of Panel System product.

1. Allen wrench 1/4"
2. #2 Phillips head screwdriver
3. #3 Phillips head screwdriver
4. Screwdriver, med slotted
5. Measuring Tape (25' or more)
6. Rubber mallet or dead blow mallet
7. Carpenter's Level (48")

In addition, the following tools will help speed up installations:

1. Drill (12v or more)
2. Set of drill bits
3. Set of screw bits #2 and #3
4. 1/4" Allen bit for drill
5. Wrench open end 10 mm (long handle is best)
6. Pliers
7. Carton knife
8. Ratchet head with 1/4" allen bit
9. 6' step ladder
10. Material handling carts

## STAGING

In an effort to make your project run more smoothly, the following is recommended:

1. Unload all products into a staging area on your job site and sort by product number.
2. Check in and count all products for accuracy and damage prior to the delivery truck leaving. Note any damages or shortages on the Bill of Lading before signing.
3. Notify the factory immediately of any shortages or damages (with photo to document).
4. Keep and maintain a clutter-free staging area – it will help speed up your assembly.
5. Protect all building walls with furniture pads or cardboard where product is leaning against them or in high traffic areas.

# Panels/Connectors



Panel runs should be installed straight and parallel to each other.

---

**WARNING:** Failure to properly install panel runs or support panels can result in product damage, personal injury, or both.

---

**NOTE:** All panels with electrically interconnected panels must be mechanically interconnected.

---

## Definitions

1. A panel run is any combination of two or more panels connected in a straight line.
2. Panels mounted at right angles to panel runs are called support panels. The minimum height for support panels should be not less than 1/2 the height of the tallest panel in the panel run (i.e., 85" high panel run should have a minimum of a 47" support panel).
3. Load bearing walls, also known as structural walls, are constructed of materials such as poured concrete, concrete block or drywall, properly attached to metal or wood studs. Drywall must be at least 5/8" thick. Wall must be restrained at the floor and ceiling and should be no more than 24" on center or 14' high.
4. Under no circumstances do we accept responsibility for determination of the structural integrity of a load-bearing wall.
5. A Loaded Panel run is any panel run that has product components of any kind attached to it. Also known as "Load Bearing side of a Panel Wall".

---

**WARNING:** Check panels for stability after installation of all components. Verify that all products are level and correctly attached. If needed, correct or adjust leveling or installation to fix stability. If needed, add additional support panels to ensure stability.

---

## Panels/Connectors / **STEP 1: Panels & Connectors**

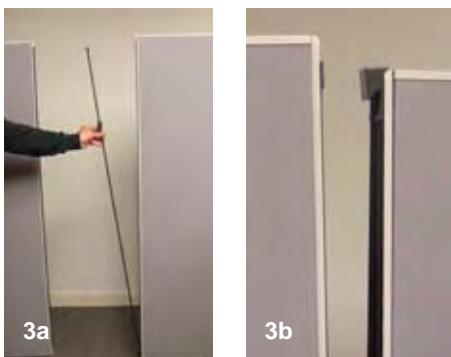

**TOOLS REQUIRED:** 1/4" allen wrench, 10mm open end wrench.

**INSTALLATION:** Start at a right angle condition in your layout. It is recommended that you identify the location using your plan to locate the connection in the office area.

**1.** Using a 2, 3 or 4 way connector, loosen the draw block at the top (finished end) of the connector with your allen wrench. The connector should easily fit over the panel wedge blocks on the end of your first panel. Tighten connector onto panel.

**a.** Loosen the Draw Block at the top of the connector.

**b.** Attach connector to panel.

**c.** Tighten connector to panel.

**2.** Add a second panel onto the connector by loosening the other draw block at the top of the connector. Install the panel in a similar manner to 1. You now have the start of your first station.

**a.** Loosen the draw block at the top of the connector.

**b.** Attach panel to connector to begin your first panel run.

**c.** Tighten connector to panel.

---

**NOTE:** It is recommended at this point that you begin to level the product in general to help in the installation and make the leveling process easier.

---

**3.** Using your panel plan as reference, determine where the next panel goes. Install the panel in a panel run as follows. Using the Draw Rod, open the rod so it will loosely fit over the panel you have installed. With the help of another installer, add the next panel in a straight line. Make sure the bottom and the top of the panel are aligned with your other panel; adjust the panel glides, if needed. Tighten Draw Rod and block to connect the two panels.

**a.** Attach Draw Rod to existing panel.

**b.** Install next panel in panel run.

**c.** Align panel and attach Draw Rod.

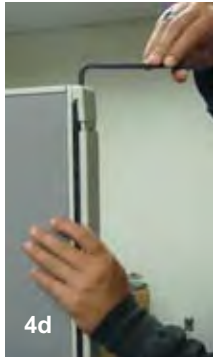
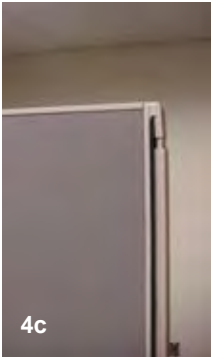
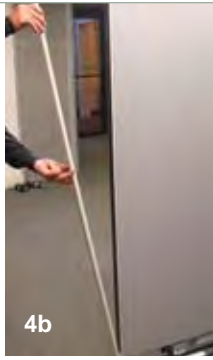

Panels should line up neatly and accurately to your plan.

d. Tighten Draw Rod to secure the panel. Check Draw Rod Top & Bottom Block to ensure they are seated correctly.

**WARNING:** Always check Top and Bottom Blocks on Draw Rod to ensure they are seated correctly.

**4.** Install the finished end cap. To install, loosen the top of the end cap with your allen wrench (1 hole). Set the bottom of the end cap (3 holes) on the bottom wedge block on the panel. Move the end cap and set over the top block of the panel and tighten.

- a. Loosen top of end cap.
- b. Attach end cap at bottom of panel.
- c. Install over top wedge block on panel.
- d. Tighten end cap on panel.

**5.** Level panels are required. Turn leveling glide with 10 mm wrench to adjust as needed. Also, realign your panels for location and square in the installation. Refer to your installation plans for location. Double check your work now; it will save time later. Level both to the earth, but also visually.

**TIP:** Use the ceiling tiles to help line up the visual aspects of your installation.

- a. Level as needed, using wrench to move glide up or down.

**6.** Wall Start applications require some additional tools. The most important are a good tape measure, level and a drill. The wall should be reinforced to prevent damage or injury. Locate on your plan the wall start. Measure the wall, and very lightly with a pencil, mark the location of the wall start. Take a panel and level it to the wall to determine the mounting height of the wall start; lightly mark the wall at the top of the panel. Locate the top 2 holes of the wall start and mark on the wall for positioning. Install your fastener to the wall at this location and install the top of the wall start. Next, level the wall start and repeat this step on the Bottom Block. (6.1)

- a. After lining up the location of the wall, start mount the top block first (this is the smaller of the two blocks).
- b. Next, attach the bottom block.



c. Cut and attach the filler strip as needed.

---

**WARNING:** Be careful when installing the wall start – you must use appropriate anchors for attaching this product to the wall. These anchors will vary depending on the field conditions. Be careful not to damage corner beads for drywall; it is strongly suggested you space off the edge of a drywall corner 2", to prevent damage.

---



**7.** When installing a variable height connection, you must remove the trim on the side of the connector you are going to attach at a variable height (always use the connector for the tallest panel you are attaching to.) To remove the filler strip, squeeze it at one end and pull toward you. Once the strip is removed, you need to unbolt the top wedge block assembly on the side you are lowering. Use a #3 phillips head screwdriver to do this. Once the block is removed, remove the connector top cap by pressing gently on the location pin to release it. Using the back of the filler strip, push the threaded plate on to the sticky tape (align to fit in connector). Using the filler strip as your guide, insert the threaded plate into the connector to the desired height connection. Reinstall the connector top wedge block using the existing screws and parts. When the wedge block is securely tightened in place, gently pull the filler strip to release it. Using a carton knife or a cutting tool, cut the filler strip to the appropriate length and reinstall the filler strip on the connector. See the next page for further installation instructions on this procedure.



a. Remove the black filler strip from the side of the connector (the side you want to lower).

b. Remove the top wedge block assembly.

c. Remove the connector top cap.



d. Placed threaded connector plate on the back side of the filler strip to use as an alignment guide for installation.

e. Using the filler strip as your guide, place the threaded plate onto the connector at the correct location.

f. At the appropriate location, reinstall the connector wedge block to create your variable height condition.

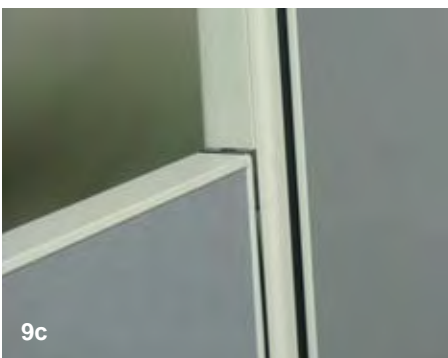
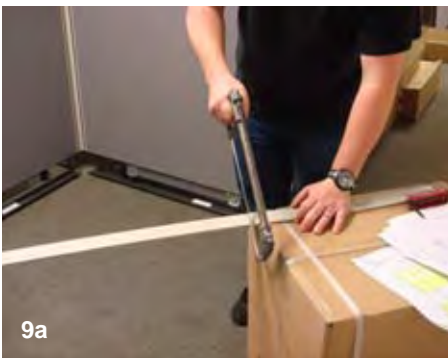

**8.** To install your variable height condition, attach the connector to your existing panel run. Use 2 people if needed. Attach the next panel in the run (generally it is easiest to attach panels of similar height). Using a standard allen wrench or a ratchet, attach the panels in the variable height location as shown.

- a.** Attach connector to existing panel run and attach the next panel in the run.
- b.** Attach the panels at the variable height location(s).
- c.** Tighten the panel wedge block to finish the installation.

---

**WARNING:** Make sure all wedge blocks and connectors are installed properly and securely before going on to the next part of the installation.

---

**9.** To install the variable height trim, take the trim strip and place it upside down on the connector, measure the length to the top and draw a line to mark for cutting. Using a small hack saw or other appropriate cutting tool, cut the trim to length. Remove the paper from the tape and align with the variable height location on the connector and press into place.

---

**NOTE:** If you remove the trim strip to change or adjust the panel, you may need to replace the double sided tape.

---

- a.** Cut to length.
- b.** Remove tape.
- c.** Align with connector.
- d.** Press into place.

### Panel Leveling

---

**WARNING:** It is very important at this point in the installation to RE-CHECK ALL CONNECTIONS to ensure safety and security. In addition, now is the time to level the system and align the stations to the plan. The panels can generally slide on the floor as needed; it may take a few people to move it at this point. Check to make sure you are not scratching or binding the flooring material; you can damage it if you are not careful. Carefully take time to line up all aspects of the job at this point – it will help during the rest of the installation.

---

# Electrical

---

**WARNING:** This energy system is designed to be installed in accordance with all local building codes. It must not be installed contrary to these codes for any reason.

---

---

**NOTE:** All Electrical components need to be mechanically interconnected.

---

## Definitions

1. Power Harnesses are the power distribution parts that carry all power through the system.
2. Power Entry, either base feed or ceiling feed are the power distribution parts designed to connect to the existing building power.
3. Receptacles are the outlet plugs designed for installation in the Power Harness to provide power within the work space.
4. Festoons are used to carry the electrical power from Power Harness to Power Harness.
5. All electrically interconnected panels shall also be mechanically connected.
6. A qualified electrician is an individual either licensed or recognized by the local building code authorities to properly wire the System 2 power system to the existing building power.

---

**WARNING:** Never attempt to install the power entries on this system without a qualified electrician. Attempting to do so can result in electric shock, personal injury, or death.

---

# Electrical / STEP 1: Festoon Installation



**NOTE:** When connecting festoon, you must take care not to connect the power system back into itself. See Diagram A (right) for the correct installation of the following conditions:

2-way connections, 3-way connections, 4-way connections

**✓ CORRECT:**

Diagram A

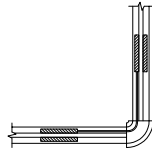

Correct 2-Way Installation

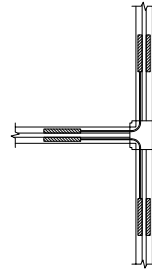

Correct 3-Way Installation

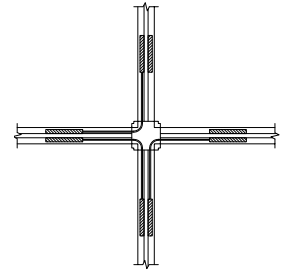

Correct 4-Way Installation

**✗ WRONG:**

**DO NOT INSTALL LIKE THESE.**

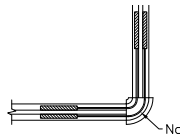

Warning: Wrong. Do Not Install Like This.

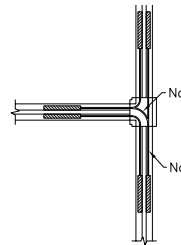

Warning: Wrong. Do Not Install Like This.

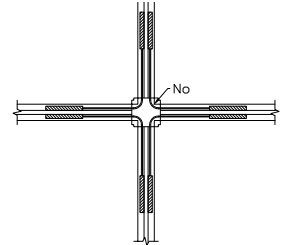

Warning: Wrong. Do Not Install Like This.

**WARNING:** The above are examples of **INCORRECT** wiring of festoons or pass through jumpers

**1.** Once you have installed the panels and connectors and have leveled the system, you can begin to install the festoons. There are two types, panel to panel and panel through post, both installed in a similar manner. Under no circumstances should you ever install 2 festoons on both sides of 2 connecting Power Harnesses or on all 4 sides of a 4-way connection, or on 3 sides of a 3-way connection or on 2 sides of a 2-way connection (see Diagram A, above). This condition **WILL CAUSE** a short circuit. Place the festoon gently onto one end of the panel Power Harness and push until it locks into the silver locking clip. Repeat on the next panel.

**a.** Push the festoon onto the Power Harness on each panel. **NOTE** the up arrow for locating the direction.

**b.** Make sure the clip is locked over the festoon to secure it.

**c.** View of a corner connection using a panel to panel festoon.

**d.** Not Shown: longer 23" Festoons are used to carry the electrical power through a 3- or 4-way connector post in a straight line.

## Electrical / **STEP 2: Receptacle Installation**



---

**WARNING:** The arrow on the festoon must be in the UP position. DO NOT FORCE THE CONNECTION.

---

**2.** Install the receptacle into the side of the Power Harness with the number or letter in the up position. Align the lower tab on the receptacle with the mechanical connection on the Power Harness.

**a.** Insert the receptacle into the Power Harness.

**b.** Secure the connection to lock the receptacle into place. Slide the receptacle until it locks into the spring clip via the mechanical connection.

---

**WARNING:** You must secure the receptacle at this point in the installation; failure to do so can cause an electrical hazard.

---

---

**WARNING:** Failure to follow these directions for connecting the Festoon can cause a short circuit and may result in product damage, electrical shock, property damage or personal injury.

---

## Electrical / **STEP 3: Ceiling Feed**

**3. NOTE:** The installation of the power entries both ceiling feed and base power entry must be made by a qualified electrician. The purpose of this description of the installation is to assist you in working with the electrician to have this product installed, UNDER NO CIRCUMSTANCES should this be attempted by a person not recognized by local building authorities as a qualified electrician.

---

**WARNING:** Power Entries should not be installed by any person(s) other than a qualified electrician. Attempting to do so can result in electric shock, personal injury, product damage, property damage, or death.

---

### **CEILING POWER ENTRY INSTALLATION**

**a.** Ceiling Power Entry is shipped with connecting hardware attached. Ceiling Power Entry attaches at the end of a panel, 2-3 or 4-way connector by means of a Draw Rod ordered separated.

**b.** To attach ceiling power entry at the end of a panel, connect Draw Rod to end of panel and Ceiling Power Entry Hardware the same way you would a panel to panel connection (See Panel & Connector Installation, page 4).

**c.** To attach Ceiling Power Entry to a connector, attach hardware on Ceiling Power Entry to connector the same way you would a panel to connector installation (See Panel & Connector Installation).

---

**NOTE:** To install the ceiling feed, gently push it into the end of the Power Harness. Make sure the clip is locked over it to secure it. Connect cable into ceiling at a junction box in accordance with local building codes and the wiring diagram below.

---

**d.** Gently push ceiling feed into the end of an Power Harness and engage locking clip.

**e.** Make sure the locking clip is engaged, to secure the ceiling feed.

# Electrical / STEP 4: Wiring Diagram – Ceiling & Base

Diagram D is the general wiring diagram for both the ceiling in feed and the base power entry. The diagram will vary depending on local codes. The building's general wiring type and specific applications for use. In general, the WYE type application is used in most single phase office type applications. Before wiring, you should ALWAYS consult a qualified electrician for the specific diagram to use in your facility and USE ONLY a qualified electrician to wire these power entries.

**WARNING:** Power Entries should not be installed by any person(s) other than a qualified electrician. Attempting to do so can result in electric shock, personal injury, product damage, property damage, or death.

Diagram D

System is rated for connection to a 3 phase system. Rating 120/208V, 3-PH WYE, 60-hz, 20 amp (CSA 15 amp) multi-wire branch circuit  
 System is rated for connection to a ground 120. Rating 120/208V, 3-PH WYE, 60-hz, 20 amp (CSA 15 amp) multi-wire branch circuit

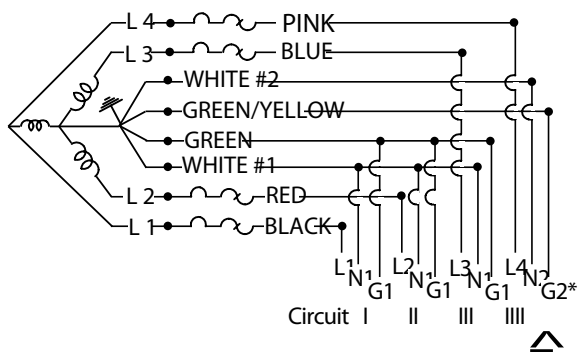

\*Separate isolated ground

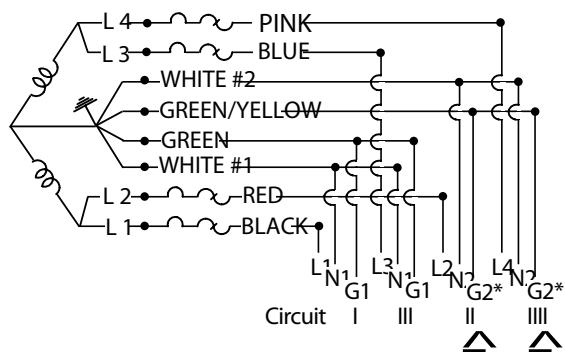

\*Separate isolated ground

**WARNING:**

Risk of fire or electric shock. This office furnishings system may be connected to more than one source of supply. All sources must be disconnected prior to any servicing. No single circuit may be powered by more than one source.

## Electrical / **STEP 5: Base Power Entry**



**5. NOTE:** The installation of the power entries both ceiling feed and base power entry must be drawn by a qualified electrician. The purpose of this description of the installation is to assist you in working with the electrician to have this product installed, **UNDER NO CIRCUMSTANCES** should this be attempted by a person not recognized by local building authorities as a qualified electrician.

---

**WARNING:** Power Entries should not be installed by any person(s) other than a qualified electrician. Attempting to do so can result in electric shock, personal injury, product damage, property damage, or death.

---

**a.** To install the base power entry, gently push it into the side of a Power Harness at a duplex location. Make sure the Power Harness snaps into the spring loaded mounting bracket. Connect cable into wall or floor at a junction box in accordance with local building codes and the wiring diagram on the previous page.

**b.** Gently push the Base power entry into the side of the Power Harness

---

**TIP:** You should feed the cable through your raceway cover at this point. This will help in the installation of the product.

---

## Electrical / **STEP 6: Connector Trim Installation**



**6.** Begin installing the connector trim pieces as shown in the following diagrams. Gently place the ends of the specific connector trim over the tabs on the end of the connector stem (for 2- and 3-way connectors only; 4-way connectors do not have trim). You may have to bend the cover slightly to place it over the tab; use caution to avoid breaking the cover. Once the cover is in place, rotate the cover upward and lock into place at the upper part of the connector stem.

**a.** Place connector trim over the tabs on the bottom of the connector stem.

**b.** Place trim over tabs

**c.** Rotate cover into the top of the connector stem and lock in place.

**d.** Connector when it's locked in place.

## Electrical / **STEP 7: Base Cover Installation Non-Powered**

**7.** Once the energy is installed as needed and the connector trim covers are on, you can begin installation of the raceway covers.

---

**TIP:** At this point, you may want to encourage the data and telephone installers to lay their cable – it can be done later, but generally works well at this point.

---

To install non-powered raceway, gently push the groove in the bottom of the raceway cover onto the rolled edge of the bottom of the raceway. Take care to line up the ends of the covers with the ends of the panel.

- a.** Gently push the raceway cover, starting at one end onto the rolled edge of the raceway.
- b.** Roll the cover up into position to lock into the lower edge of the panel.
- c.** Gently tuck the lip on the top of the raceway cover under the metal edge at the bottom of the panel.
- d.** When finished, the raceway cover will stay in place by itself.

## Electrical / **STEP 8: Base and Trim Cover Installation**

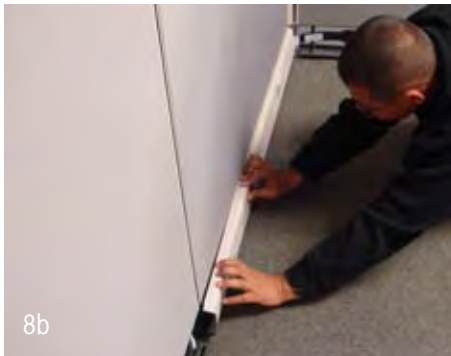

**8.** All installation of the powered raceway covers is identical to the procedure listed above for the non-powered raceway covers except alignment with the receptacles or the base power entry are critical for installation.

- a.** Alignment with receptacles or base power entries are critical.
- b.** Once alignment is complete, install like the non-powered covers listed above.
- c.** Install Window Covers as needed; this can be done either before or during Base Cover installation.
- d.** Install cover as above in 3.1 through 3.4.

## Electrical / **STEP 9: Finished End Trim Cover**



**9.** To install the Finished End Trim Cover, locate the tabs at the bottom of the raceway end cap (3 tabs). Place them into the holes in the raceway at an end cap location.

**a.** Place the tabs on the bottom of the end cap into the holes on the raceway.

**b.** Rotate the end cap up to the bottom of the panel.

**c.** Lock end cap into the tab at the bottom of the panel. Adjust tab with a flat tip screwdriver if needed for a firm fit.

**d.** Finished end trim cover when it's installed.

## Storage/Shelves/Flipper Doors / **STEP 1: Open Shelves**



**1.** The following installation instructions are for open shelves. This instruction is for Half Height and Full Height. It is also the beginning stage of installation for a flipper door. Begin the shelf installation by placing the rear of the shelf end at a slight angle to the panel (about 85 degrees). Insert the bracket at the rear of the shelf end into the slots on the panel and rotate the shelf end to 90 degrees to the panel. You should feel the shelf end drop into place; if you do not, you should gently tap the shelf end downward to lock into place.

---

**WARNING:** Make sure the shelf end is secure at this point. When installing the shelf and/or flipper door, this will be critical.

---

**a.** Insert the shelf end into the slot on the panel; you will need to insert it at approximately an 85 degree angle to place it in the track.

---

**TIP:** It is a good idea to install all shelf ends in a given cubicle at this point.

---

**b.** Move all shelf ends 90 degrees to the panels at this point to begin the next step of the installation.

---

**WARNING:** Make sure the shelf end is secure at this point.

---

## Storage/Shelves/Flipper Doors / **STEP 2: Shelf Pan Installation**



**2.** To install the shelf pan, you first need to insert the shelf bolts into the shelf ends. If you are installing only a shelf, insert 4 bolts. If you are going to install a flipper door, insert 8 bolts at this point. With the rectangular slot towards you, gently set the back of the shelf on the 2 lower rear screws. Pivot the front of the shelf onto the front screws. If you are only installing a shelf, tighten all 4 screws at this point to secure the shelf.

---

**TIP:** If you are going to install a flipper door or an additional shelf to this pair of shelf ends, do not tighten the screws at this point — proceed to next step.

---



**a.** Lower the rear of the shelf pan onto the rear bolts.

**b.** Lower the front of the shelf onto the front screws.

**c.** Using a #2 phillips screw driver, tighten all 4 screws at this point to secure the shelf to the shelf ends.

---

**WARNING:** Check to make sure the shelf is securely locked onto the shelf ends. If you are proceeding to install a flipper door or additional shelf, you must repeat this procedure to ensure the security of the shelf.

---



## Storage/Shelves/Flipper Doors / **STEP 3: Flipper Door Installation**



**3.** The installation of the flipper door is similar to a shelf. You must insert the bolts on the shelf end first. While holding the door in place, set the rear of the flipper door onto the rear shelf bolts at the top of the shelf; rotate the door onto the front bolts. Tighten all bolts, including the shelf pan bolts at this point to make your flipper door secure.

---

**TIP:** You may need to loosen the shelf bolts to make this installation easier. RE-TIGHTEN.

---



- a.** Insert the rear of the flipper door onto the rear upper shelf bolt.
- b.** Rotate the flipper door onto the front upper shelf bolt.
- c.** Tighten all bolts. You may need to shift the door slightly to get to the rear bolts. RE-CHECK your shelf bolts and tighten, if needed.

---

**TIP:** Move the door slightly to access the rear bolts.

---



# Worksurfaces / **STEP 1: Corner Worksurfaces and Extended Corner Worksurfaces and 120° and 135° Worksurface Installation**

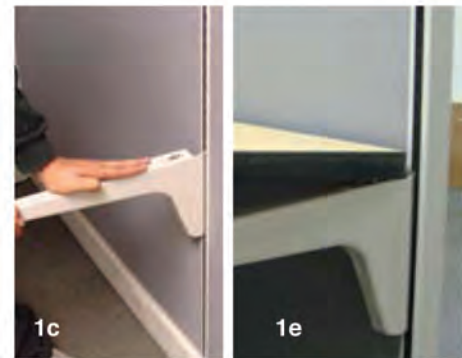
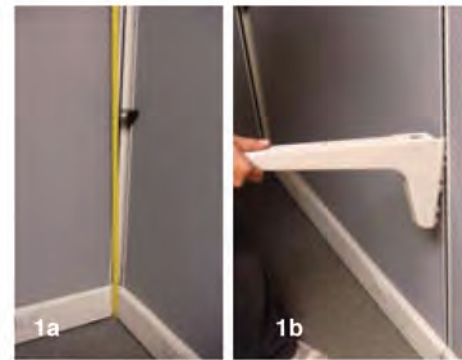

**NOTE:** Corner Worksurfaces should be installed before installing adjacent worksurfaces

- a. Install Corner Bracket provided in the corner at the desired height. Ensure all bracket hooks are fully seated in the slots.
- b. Install Cantilever Bracket on Hanger Frame by inserting the tab on the top hook of the Cantilever Bracket into the Hanger Frame slot at the desired height.
- c. Rotate bottom of Cantilever bracket into Frame to engage all hooks. Repeat procedure for Cantilever on other side of the worksurface.
- d. For Corner Worksurfaces 60" to 84" wide, install center Support on center Frame at the same height as the Cantilevers on the right and left side.
- e. Push down on all worksurface supports to ensure all hooks are fully seated in slots.
- f. Install Shoulder Screws at the back of the worksurface. Do not install front spacer yet.
- g. Install Worksurface on the Cantilever Brackets (one side at a time)  
Mount the screws provided up through the holes in the cantilevers and into the worksurfaces to secure the worksurface to the cantilever brackets.
- h. For 60" wide or greater worksurfaces, align Center Support
- j. Install adjacent worksurfaces as required.
- k. Attach Ganging Plates between adjacent worksurfaces.

# Worksurfaces / **STEP 2: Rectangular Worksurface Installation**

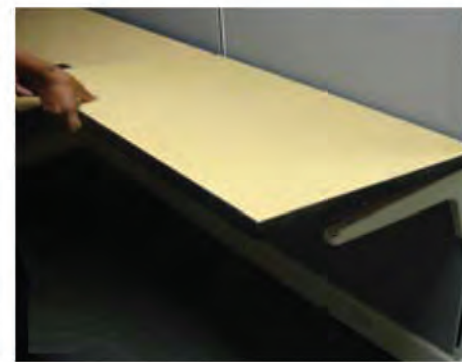

---

**WARNING:** All work surface support used to support the same worksurface must be mounted at the same height.

---

**a.** Install Cantilever Bracket on Hanger Frame by inserting the tab on the top hook of the Cantilever Bracket into the Hanger Frame slot at the desired height. Rotate bottom of Cantilever Bracket into Hanger Frame to engage all hooks. Repeat procedure for Cantilever on other side of the Worksurface.

**b.** For Worksurfaces 60" to 84" wide, install center Support on center Hanger Frame at the same height as the Cantilevers on the right and left side. Push down on all work surface supports to ensure all hooks are fully seated in slots.

**c.** Mount screws provided up through the holes in the cantilever brackets to anchor and install the worksurface.

Install adjacent worksurfaces required. Attach Ganging Plates between adjacent worksurfaces in underside of the worksurface.

## Worksurfaces / **STEP 3: Transaction Surface Installation**

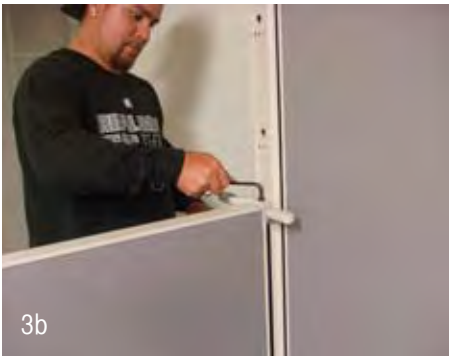

**3.** Transaction Surface Support. There are three (3) types of Transaction Surface Supports. End support is used to support the Transaction Surface placed at the end of a panel run. Mid-end Support is used to support the Transaction Surface placed at 2-3 or 4-way connector post. Center Support is used to support the Transaction Surface in a straight line connection (at a Draw Rod).

Installation of a Rectangular Transaction Surface at the end of a panel run and a 2-way connector:

- a.** Remove top connector block at panel and post connection.
- b.** Install Mid-End Support in place of connector top block.
- c.** Remove top block on finished end and install end support on finished end in place of the top block.
- d.** Reinstall finished end and secure to panel end.
- e.** Position Transaction Surface on top of supports and secure with screws provided.

## Pedestals/File Cabinets / **STEP 1: Pedestals & Supporting Lateral Files**



**1.** All pedestals (except mobile pedestals) and Support Lateral Files require attachment to the work surface they are supporting. It is important that you check your pedestal height in STEP 4 Work Surface Installation. If the height is incorrect you will have to reset the height of the worksurfaces accordingly. First step is to open the drawer on your pedestal (the key is attached to the top of pedestal for shipping). Remove the top two box drawers or the file drawer depending on your configuration. Using the screws provided and with the pedestal in place, attach the screws at the front and the rear of the pedestal to support it. Replace the drawers.

**a.** Open the pedestal.

**b.** Remove the drawer by lifting the dislodging bracket and pulling forward on the drawer.

**c.** Insert the mounting screws into the locations at the front and rear of the pedestal.

**d.** Carefully reinsert the drawer into the track.

---

**TIP:** Always recheck the drawers for correct operation after installing the pedestal. Also check to make sure the lock works correctly.

---

## Accessories / **STEP 1: Tack boards & Markerboards**

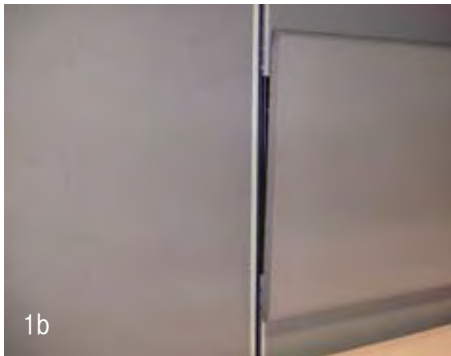

**1.** Insert the tack board mounting brackets on to the panel hanger frame at the desired location. Attach the shoulder screws to the tack board approximately 4" from the top of the tack board, about 1/2" in from the edge of the tack board, the second screw is located exactly 7" below the first. Slide the tack board screw into the tear drop of the tack board bracket and the top notch of the bracket. Check to make sure the tack board is level.

**a.** Insert the bracket on to the panel.

**b.** Attach the tack board to the top notch and lower tear drop.

**c.** Completed tack board should look level.

## Accessories / **STEP 2: Tool Bars**



### **2.** Installing Tool Bars.

**a.** Insert right side bracket at end of tool bar.

**b.** Insert right side bracket into the hanger frame slots at the desired height, and push down.

**c.** Insert left side bracket into the hanger frame slots, at the same height as right side and push down.

**d.** Make sure the tool bar is leveled.

## Accessories / **STEP 3: Work Tools**

---

**3.** All work tools require a tool bar of appropriate length. The tools have a small C-shaped clip at the rear. To insert the tool, simply place at an angle to the bar and insert it. Drop into position.

**a.** Attach work tools to the tool bar as needed.

## Accessories / **STEP 4: Cord Managers**

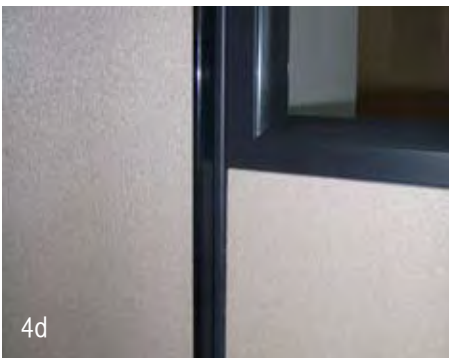

**4.** The cord manager is sold in 24" lengths and designed to be cut to length in the field and placed to manage and control cables in the stations. The following shows installation of Cord Manager.

- a.** Task light cord without Cord Manager in workstation.
- b.** Insert cord into Cord Manager.
- c.** Insert Cord Manager into hanger frame.
- d.** Cord Manager neatly hides cords.

## Accessories / **STEP 5: Tasklights**

---

**5.** Set the rear edge of the light and mounting bracket on the rear lip underneath the shelf or flipper unit. Rotate up into place, move the front of the mounting bracket and snap into place under the shelf or flipper door.

**a.** Mounting brackets are shipped attached to the tasklight.

**b.** Place the rear of the task light bracket on the lip of the shelf.

**c.** Slide the front of the mounting bracket and push into place under the shelf, and tighten knob.